

Automatic Circular Blade Sharpening Machine

S.Hari Shankar Elango¹ and E.Esakki Vigneswaran²

¹II M.E,Embedded System Technologies, ²Assistant Professor., Department of ECE,
Sri Ramakrishna Engineering College, Coimbatore, Tamil Nadu, India
E-mail: steve.elango@gmail.com,

Abstract - The main purpose of this paper is to design and implement an Automatic circular blade sharpening machine using PIC16F877A and latest motor drivers .In this system we are having four outputs and two inputs. The four output devices are turntable motor, grinder motor, feed motor and a solenoid coil. And the two inputs are cycle start switch and home position sensor. This machine is designed to grind the blade in the shape of circular automatically which is designed for the beef flesh cutting application. The circular blade is to be mounted on the blade holder only by adjusting the center screw of the blade holder. Then we have to adjust the grinder motor position according to the diameter of the blade. By pressing the auto cycle start button after the completion of all the settings, the grinding cycle begins. After the grinding process the grinder motor will be settled down in its home position. And then the solenoid will be activated and it removes the burr with the help of turn table motor movement and thus the cycle will be completed.

I.INTRODUCTION

An automatic circular blade sharpening machine is a specific application oriented project. It is designed and implemented only for sharpening or grinding the circular blade. In order to increase the process speed we have designed the machine to perform the complete process automatically.

The process cycle begins by pressing the cycle start button. When the cycle start button has pressed the controller starts to execute the code which has written in the controller. In this project we use hi-tech C compiler for compiling the code written in high level language.

The timer starts to run at the time of pressing the cycle start button. After 3.051 sec's the grinder motor starts to rotate. After certain time the turn table motor starts to run at slow speed and ramps up to high speed within certain time period. Before executing the program we have to made mechanical, position settings of output devices according to the diameter of the circular blade. The controller checks whether the feed motor is kept at home position or not. The home position of the feed motor can be identified by the controller with the help of an infrared sensor.

After checking the home position, the controller starts the feed motor to run at slow speed.The feed mechanism is

a linear actuator. The linear movement of the linear actuator is 0.001inch/step. The no load current of the feed motor had calculated in advance through experiments. The feed-motor rotates slowly and move the grinder motor towards the turntable motor slowly by very small steps. The feed motor moving the grinder motor towards the turntable motor till it reaches the circular blade.

The engagement of the grinding wheel and the blade is identified by comparing the current during engagement and the no load current. The current sensing unit with MAX437 is used here to compare the current. When the increase in current is sensed the feed mechanism suddenly, it stops feeding. Then the feed motor starts to rotate in reverse direction, and thus it pull the grinder motor two steps in backward direction. Adds specified offset to set target (New idle current + 70).

Then the feed mechanism starts to move the grinder motor in forward direction until the grinder motor current is smaller than or equal to the calculated target current. Adds the minimum load across each revolution (Example if the minimum load on the first revolution is 5,8 on second and 3 on the third revolution.

It would accumulate to $5+8+3=16$) until it hits the required amount of work. If it does not reach the required amount of work within 3 revolutions it repeats this process with a higher load (+105 instead of +70) and it will continue the grinding until it reaches 750 work (or until it hits 155 revolutions).Remember that this is adding the lowest current reading it finds on a revolution taking measurement on each 5 degree segment of the blade.(it has slight offset so it does not take readings on the exact sane spots on the blade every revolution).

Move grind wheel up one step(to prevent over grinding).Gets idle amps adds sharpening offset, steps feed motor until near target amps (+/- 13) [same process as above].Engages steel, adds the minimum load across each revolution until it hits the required amount of work (100) or maximum number of revolution are exceeded in which case it exit with an error.

After the grinding process the spark out process will be continue. At first we have to get the idle amps and adds spark out offset (65).Steps feed motor until near target

amps(+/- 6). Count 12 revolutions and releases steel on revolution #8. Sparks on last 4 revolutions. And at last shut down the auto edge machine.

II. RELATED WORKS

BETTCHERT Industries, Virnilion, U.S.A , designed and implement the system based on Auto Edge Automatic blade sharpener using the FPGA IC LPC768BN. The FPGA IC, which is used here is a controller is not available in the current market. And also the power consumption of the controller is very high.

Due to unavailability of the component in the market, it is very difficult to replace the component (controller), if any problem occurs. The other electronic components such as motor drivers are also not available in the market. So that the same problem will be happen here. The advantage of the project is,

- a. Cost of the IC LPC768BN is very cheap when compare to the other controller IC's.
- b. Programming in the chip is also very simple.

There are some disadvantages in this project and are,

- a. The unavailability of the passive and active components in the market.
- b. It is difficult to reprogram or modify the existing program in the controller chip.

Arvind N.Nakia, Mahesh A.Makwana & Ramesh r.Gajera[2013], proposed the article based on an external plunge grinding machine with control panel automation technique based on Mitsubishi PLC system. Automation is the process of handling various parameters of process like temperature, flow, level etc. without presence of responsible person.

In industrial field, Automation and control have greatly improve in industrial manufacturing in the world. Technological advancement in automation and control over the past decades have contributed greatly to improve the productivity of virtually all manufacturing industries throughout the world.

In the development of automation controllers the trend has been to move towards soft controllers so as to provide better control, more flexibility and more reliability with

intelligent diagnostics of machine faults. So industries have gradually moved from conventional relay logic control to programmable logic control and then to computerized numeric control.

In this paper all the required control, induction and servo motor performance data with ladder logic programming will be taken to a personal computer via PLC for further analysis. Various results are obtained and discussed. Almost any production line, machine function or process can be automated using a PLC. The speed and accuracy of the operation can be greatly enhanced using this type of control system.

The use of programmable logic controllers (PLCs) with power electronics in electric machines applications has been introduced in the manufacturing automation. But the biggest benefit in using a PLC is the ability to change and replicate the operation or process while collecting and communicating vital information.

The advantages of this system are,

- a. The PLC is very robust so that it can with stand in industrial temperature and dusty environment.
- b. The ladder logic program is very is simple when compare to other high level languages such as C,C++ used in microcontrollers.

There are some disadvantages in this project. They are,

- a. It occupies more space, so that it is not compatible.
- b. The cost is very high when compare to other embedded systems.

III. PROPOSED SCHEME

The above mentioned survey's reveal the various faults which occur in automatic circular blade sharpening machine and also exclaims us to analyze those faults as when needed. All the above surveyed papers had undergone some serious disadvantages which has to be solved out. To overcome those serious disadvantages, the proposed design has been implemented.

Here the controller PIC 16F877A controls the process cycle. The system has to be designed to overcome the drawbacks such as enormous heating of driver IC .

IV. BLOCK DIAGRAM

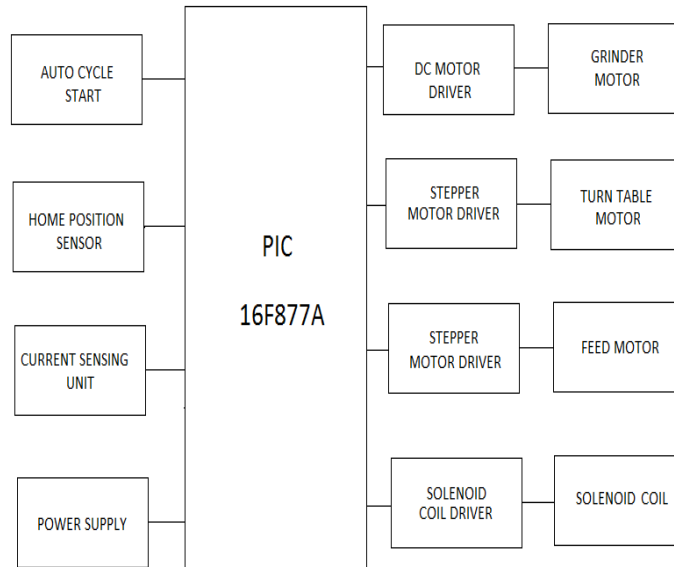

Fig.1 Block diagram of the automatic circular blade sharpening machine

The figure 1 shows the block diagram of the automatic circular blade sharpening machine. The automatic circular blade sharpening machine consists of 4 outputs and 3 inputs. The input and output devices are interconnected with the controller PIC16F877A. The total system is powered by the switch mode power supply of 24V/4A.

V. EXPERIMENTAL RESULTS

The proposed system consists of PIC 16F877A controller unit with all interfacing components. The controller unit is shown in the Figure 2.

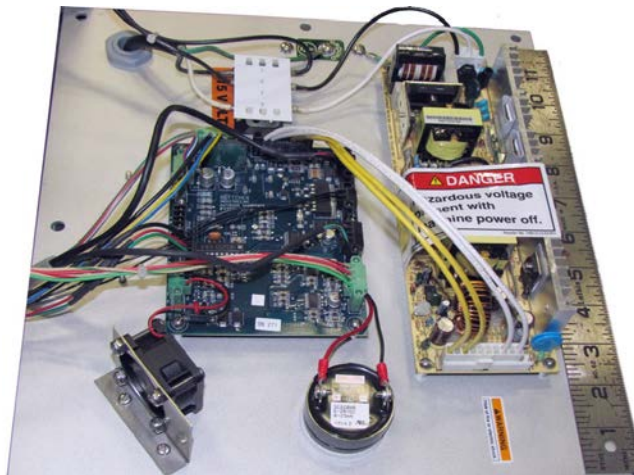

Fig.2 Controller Unit

The machine assembly and various mechanisms in the machine is developed by the mechanical engineers. The front panel consists of various mechanical assemblies such

as grinder motor and feed motor assembly, solenoid coil assembly, and turn table motor assembly and are shown in the Figure 3.



Fig.3 Front panel

The switch in red color is the power on/off switch. When the switch is turned on, the power led will indicate that the machine is turned on. At this stage the machine is only turned on and it doesn't start its work. To start the cycle process the cycle start button have to pressed, which is shown in green color.

If there is any fault in the machine it will be indicated by the fault LED which in red color. If there is no problem in the machine and it will be indicated by the machine through the ready led which is shown in the Figure 4 in green color.



Fig. 4 Switches and LED's

The timer starts to run at the time of pressing the cycle start button. After 3.051 sec's the grinder motor starts to

rotate. A 5V DC motor is used here as the grinder motor. The turn table motor is shown in the Figure 5.

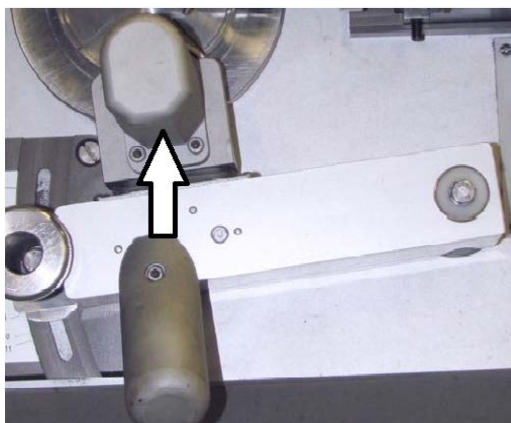

Fig.5 Grinding motor position

After certain time the turn table motor starts to run at slow speed and ramps up to high speed within certain time period. Before executing the program we have to made mechanical, position settings of output devices according to the diameter of the circular blade.

The controller checks whether the feed motor is kept at home position or not. The home position of the feed motor can be identified by the controller with the help of an infrared sensor. After checking the home position, the controller starts the feed motor to run at slow speed.

The feed mechanism is a linear actuator. The linear movement of the linear actuator is 0.001inch/step. The no load current of the feed motor had calculated in advance through experiments.

The feed-motor rotates slowly and move the grinder motor towards the turntable motor slowly by very small steps. The feed motor moving the grinder motor towards the turntable motor till it reaches the circular blade. The turn table motor is shown in the Figure 6.

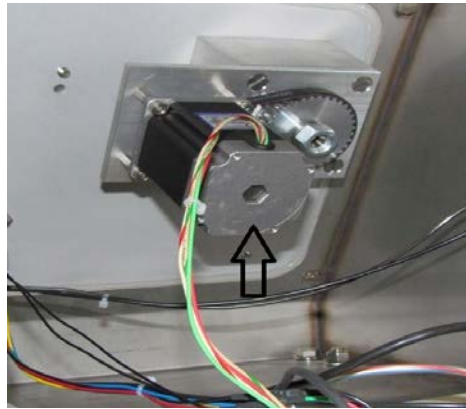

Fig.6 Turn table motor

Then the feed mechanism starts to move the grinder motor in forward direction until the grinder motor current is smaller than or equal to the calculated target current. Adds

the minimum load across each revolution (Example if the minimum load on the first revolution is 5,8 on second and 3 on the third revolution.

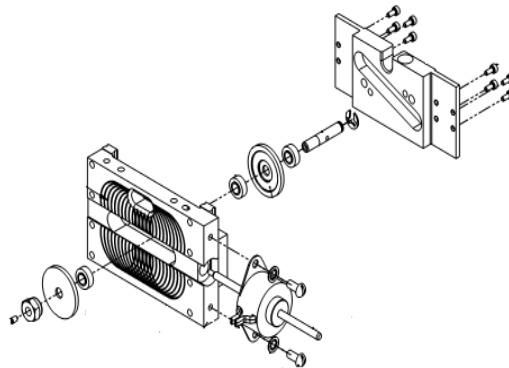

Fig. 7 Feed motor mechanism

It would accumulate until it hits the required amount of work. If it does not reach the required amount of work within 3 revolutions it repeats this process with a higher load and it will continue the grinding until it reaches 750 work (or until it hits 155 revolutions). Remember that this is adding the lowest current reading it finds on a revolution taking measurement on each 5 degree segment of the blade.

VI. CONCLUSION AND FUTURE WORK

Thus the proposed system satisfies all the requirements which are all we decided as our needs at the beginning of

the project. The Automatic circular blade sharpening machine was designed and implemented using PIC16F877A and latest motor drivers. In this system we are having four outputs and two inputs. The four output devices are turntable motor, grinder motor, feed motor and a solenoid coil. And the two inputs are cycle start switch and home position sensor.

This machine is designed to grind the blade in the shape of circular automatically which is designed for the beef flesh cutting application. The circular blade is to be mounted on the blade holder only by adjusting the center

screw of the blade holder. Then we have to adjust the grinder motor position according to the diameter of the blade. By pressing the auto cycle start button after the completion of all the settings, the grinding cycle begins. After the grinding process the grinder motor will be settled down in its home position. And then the solenoid will be activated and it removes the burr with the help of turn table motor movement and thus the cycle will be completed.

As a future work all the process of the automatic circular blade sharpening machine will be designed and implemented using low power controllers such as MSP 430. And also it will be planned to design a portable multi operation machine with low power consumption.

REFERENCES

- [1] Dr.B.Jayachandraiah, O.Vamsi Krishna, P.Abdulla khan, R.Ananda Reddy, 2014. "Fabrication of Low Cost 3-Axis CNC Router", International Journal of Engineering Science Invention, Vol. 3, pp.01-10.
- [2] Aravind N.Nakia, Mahesh A.Makwana,Ramesh R.Gajera, August 2013. "An External Plunge Grinding Machine With Control Panel Automation Technique Based On Mitsubishi PLC System", International Journal Of Electrical Engineering Technology, Vol. 4, pp. 197-204.
- [3] Mr. Prakash M.Parmar, Prof.Vikas R.Gondalia, Prof.Niraj C.Mehta, 2014. "Review On Advance Automation Of Conventional Lathe Machine",International Journal Of Electrical Design And Research,Vol.2, pp. 123-139.
- [4] Neha Kaushal, Rahul Sharma, March 2014, "Control And Automation of Cylindrical Grinder Using PLC, Drives and HMT", International Journal Of Engineering And Innovative Technology, Vol.3., pp. 20-22.
- [5] Pei Ruilin n Fang Ying, "Variable Structure Speed Regulation of induction motor in Steel Manufactures", IEEE international Conference, Vol. 1, pp.710-714, 2005.
- [6] Zhou Xu-Yan, Lia Qiang, Tan Bin, July 2010 "Research of CNC System used on External Cylindrical Grinder based on Embedded Technology", Third International Symposium on Electronics Commerce and Security Workshop,pp.264-267.